

COLLINS TORSIONAL MECHANICAL FILTER

8- POLE DESIGN

ELECTRICAL CHARACTERISTICS	0°C to 60°C	
	VALUE	TOLERANCE
CENTER FREQUENCY	455.00 kHz	±.50 kHz
BANDWIDTHS F3H - F3L F60H - F60L	10 kHz 20 kHz	±.50 kHz max.
PASSBAND RIPPLE	3.0 dB	max.
INSERTION LOSS	4.0 dB	max.
STOPBAND 355 kHz to 425 KHz 425 KHz to F60L F60H to 485 kHz 485 KHz to 555 KHz	50 dB 60 dB 60 dB 50 dB	min. min. min. min.

NOTE: The maximum signal input voltage is 1.0 volt RMS.

ROCKWELL COLLINS
FILTER PRODUCTS

526-8735-010

ENGINEER: D. P. Havens

FILTER TYPE: SYM

REV. LTR. --

APPROVED: F. L. Fanthorpe

FSCM NO.
2X491

DATE: 2-28-01

ENVIRONMENTAL REQUIREMENTS:

OPERATING TEMPERATURE RANGE: 0°C to +60°C

NON-OPERATING TEMPERATURE RANGE: -30°C to +85°C

VIBRATION: MIL-STD-202, Method 201, 10 G's, 10 Hz to 55 Hz

SHOCK: MIL-STD-202, Method 213B, 50 G's, 11 ms, half-sine

MECHANICAL REQUIREMENTS:

CONSTRUCTION: Sealed, Non-Hermetic

CASE STYLE: PS

MARKING: Rockwell Part Number
Date Code

TEST CIRCUIT:

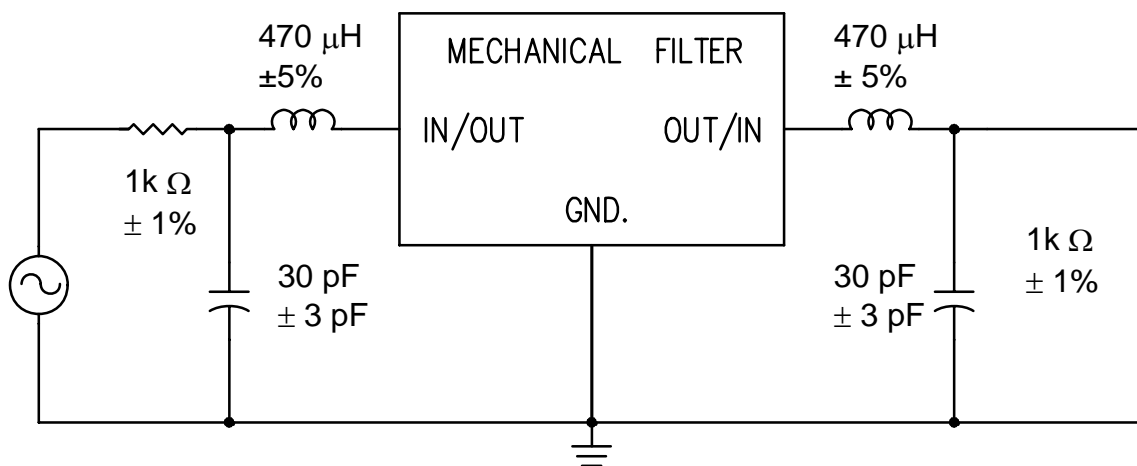

NOTE: 30 pF INCLUDES ANY BOARD STRAY CAPACITANCE.

ROCKWELL COLLINS
FILTER PRODUCTS

526-8735-010